

Acid gas combustion systems for sulphur recovery units: PILLARD burner operation on SRU of TOTAL Lacq gas plant (France)

By Pascal Laroche, Senior Engineer, PILLARD (France)
and Jean Nougayrède, Consultant - Sulphur Expert, NGD Consult (France)

The most widely used process in Gas Plants and Refineries for sulphur recovery from Acid Gases is the modified Claus Process (fig 1). It typically includes the use of a combustion/reaction step followed by 2 or 3 catalytic steps to achieve a sulphur recovery of 95-97.5%.

Each of these process steps involves the use of specific burners:

- the main AG burner on the front of the reaction furnace ensures the combustion of one third of H_2S to SO_2 . Good combustion conditions are essential for the conversion of the Claus reaction taking place in the reaction furnace and in the subsequent catalytic converters.
- the in-line auxiliary burners. They are needed to reheat the process gas typically up to 230 -210 °C prior to the catalytic converters. Most usually they burn a portion of AG feed, but sometimes fuel gas. The combustion quality is very important for the activity of the following Claus catalysts.

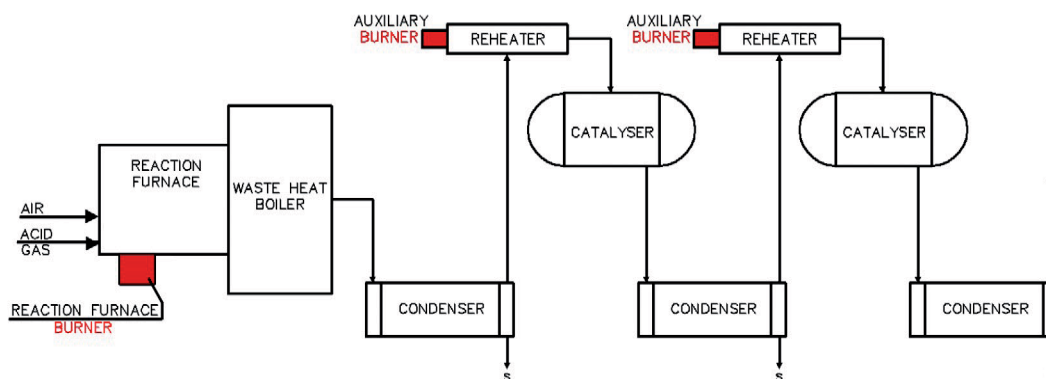

Fig.1 : Typical Claus process diagram

Nowadays, the TOTAL Natural Gas Plant at Lacq (France) includes 2 Sulphur Recovery Units: The first (1200t/d) is designed with two Reaction Furnaces in parallel, and the second (600t/d) with one single Reaction Furnace (see fig.2). All are equipped with PILLARD Acid Gas burners (see fig.3) that have been operating successfully since their first commissioning (respectively 1987 and 1991).



Fig.2 : Reaction furnace - View from the bottom



Fig.3 : Acid Gas burner - Front view

The design and construction of the PILLARD acid gas burners have proven to be of exceptional reliability and durability. The PILLARD burners installed on the 600t/d SRU have operated for a non-stop run of five years – from 1998 to 2003 – whereas the duration of a normal run is three years. Good combustion performance has been maintained throughout this run, particularly with regard to the subsequent catalysts that did not show any detrimental loss of activity.

The reaction furnace burners are designed with **double impulse Acid Gas injectors and are installed tangentially on the side of the combustion chamber** (see fig.4). This configuration is aimed at achieving an intensive confinement of the Acid Gas flame at the front end of the chamber, which improves the stabilisation of the flame, particularly in the case of lean Acid Gas. In addition, this configuration results in a better use of the combustion chamber where the Claus reaction can reach complete conversion thanks to a better homogeneity of temperature and gas mixture.



Fig.4 : Acid gas burner tangentially installed on the side of the combustion chamber

The Pillard burners at Lacq have processed Acid Gas with H₂S content ranging from 35 to 64%vol.

Nowadays the normal operating capacity of the burners is 32 000 Nm³/hr to 38 000 Nm³/hr for an Acid Gas averaging 58% vol. H₂S. The high flexibility of the burners with a turn down ratio of 5 to 1 enables the operation requirements to easily be met, and to accommodate the H₂S content variations due to the decline of the Lacq gas field.

Additionally, the 600t/d SRU is equipped with a PILLARD auxiliary burner (acid gas or fuel gas fired - see fig.5) for reheating the process gas prior to the first catalytic Claus reactor. This equipment has shown the same high level of reliability, flexibility and durability.

Acid gas flames have a very low UV emission and it is therefore not reliable to check the flame presence with a standard UV type flame detector. For this reason the UV flame detection unit cannot be used and this is detrimental to safety.

The new Packscan Flame Detector developed by PILLARD (see fig.6), which is more sensitive than standard detectors, was tested at the Lacq plant last November and has proven its ability for detecting acid gas flames.

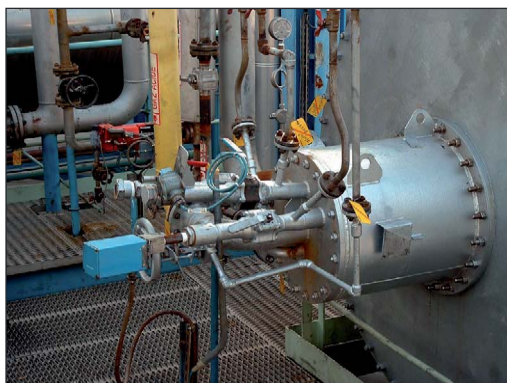

Fig.5 : Auxiliary burner, Acid Gas and fuel gas fired



Fig 6: Packscan Flame Detector

Conclusion : PILLARD have numerous references supplying reliable and flexible Acid Gas burners meeting the widest range of the Claus process requirements. The long experience and the actual performance of the PILLARD burners at the Lacq plant confirm PILLARD's expertise in this field.