

Continuous research pays dividends

A brand new set of rules

Innovation has always been at the heart of the successful history of Italian material handling experts Fives Cinetic. In fact, a distinctive factor of the company's evolution has been the continuous research of innovative approaches to logistical problems of its customers, introducing innovative products and technologies to solve those problems.

Since the introduction of the Shoe Sorter in the '70s, the company led a revolution in the automation of sortation by creating and developing new technologies. The apex was the introduction of Cross Belt technology in the '80s and the Parcel Singulator in the '90s.

These technologies are now considered a 'must' in the industry, and represent the reference solutions in most applications.

Parallel to its innovations in sorting technologies, the company has also developed a range of innovative applications that adapt basic technology to a variety of specific customer needs.

An example of this is the Cross belt technology, originally developed to sort the difficult items in the postal applications (the rest mail), has nowadays applications that range from airports to distribution centres in retail, mail order, order assembly and shipping.

The cross belt has been implemented in the largest parcel sorting centres. Its higher throughput has also enabled the evolution of the sorting systems from a 'multi step sortation', with primary, secondary and often tertiary sorting into a 'single pass' sorting system, where each item is allocated to its final destination by a single sorter. This has alleviated common problems of unbalance and deadlocks.

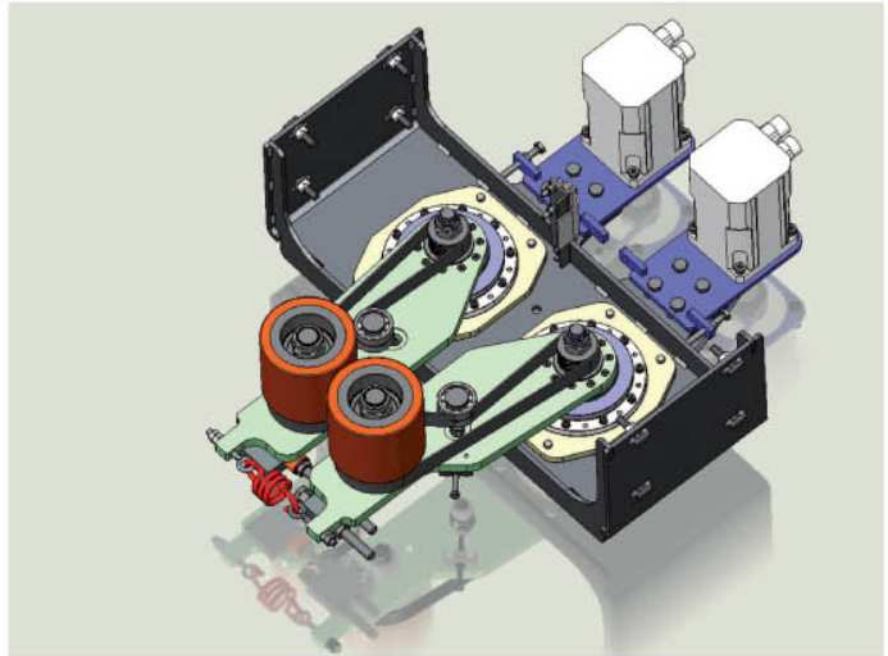

Despite the impressive advantage of its superior throughput, the real highlight of the Fives Cinetic sorters has been their outstanding reliability that allows a very low level of maintenance.

The latest innovative step has been the creation of a sorter with the outstanding performance of the first in class sorter SBIR MD, adapted for the smaller depot, where low throughput does not allow investment in high level technology.

The SBIR DYNAMIC is the perfect answer to the problem: it has the excellent reliability of the parallel design circular sorter with all other features comparable with the normal level of requirement of a medium size depot.

The innovative approach on the main solution is matched by the same innovative approach in the design of the components and in the choice of subsystems. From the controls to the power distribution a series of proven technologies are applied in an original set-up.

A distinctive example of this approach is represented by the original driving system

of the circular sorters SBIR cross belt family. Since the '90s, the attention to the environment and to security of operation has driven our R&D teams to design a propulsion system based on standard reliable components. This includes brushless motors providing high power efficiency in a jam-proof design.

The development has made Fives Cinetic one of the few sorter suppliers not using linear inductive motor technology, and allows us to proudly confirm that our choice proved to be right.

Fives Cinetic's driving unit is also the most energy efficient, outdoing the latest development in synchronous inductive motors. It has proved to be as maintenance free as the inductive motors are, but with higher reliability and a record of zero-downtime on sorters' operation over a 10 years reference period.

The 'shop of good ideas' is still at work, and Fives Cinetic R&D team will continue to prepare the solutions that drive the progress of the material handling industry of the future.

www.fivesgroup.com