

Fives Cail Newsletter - Jan. 2009 - No.1

Fives Cail's NEW BEET EXTRACTION TECHNOLOGY

In the sugar beet industry, **Fives Cail** proposes a wide range of products for process lines, all designed for reliability, performance, automation and energy savings. Equipped with the latest version of Fives Cail's equipment, the Bogazliyan sugar factory built in Turkey in 2005 (10 000 tb/d) is the most modern sugar beet plant in the world.

Fives Cail has 60 years of experience with beet diffusers and more than 220 references; in 2008 it developed a new beet extraction technology which is comprised of the **TowerMax®** (tower diffuser), the **EcoMixer®**, (a countercurrent cossette mixer) and **peripheral equipment** (heaters, defoamers, pulp strainers and sand removers, etc.).

TowerMax®

TowerMax® is a countercurrent tower diffuser which is comprised of:

- a base with shaft supporting and bearings, vertical and horizontal screens, cossettes inlets and juice outlets;
 - an extraction zone with moving and fixed blades to transfer cossettes from the bottom to the top of the tower;
 - an upper part with motorization and 2 pulp extraction screws.
- All parts in contact with products are made of stainless steel.

Residence time of the cossettes in the extraction zone is between 90 and 120 minutes. Screens are cleaned permanently by scrapers. An additional cleaning by juice is done when necessary.

TowerMax® is designed with proven process rules. Construction rules emphasize robustness associated with costs analysis through local manufacturing possibilities. Reliability and control including safety alarms ensure low maintenance cost and optimized operation.



EcoMixer®

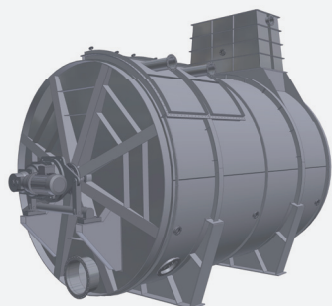

EcoMixer® is a countercurrent cossette mixer which includes:

- a body with fixed arms;
- a motorized rotating shaft with moving blades and mixers;
- screens for defoamed juice and raw juice.

All parts in contact with products are made of stainless steel.

EcoMixer®'s design and construction standards, as well as its operating rules are as reliable as TowerMax®.

Typical operating data for Fives Cail extraction plants are:

- Draft: 95 to 115% on beet
- Sugar losses: 0.2 to 0.25% on beet
- Steam consumption: 1.3 to 1.7% on beet
- ΔT juice-cossettes: 10 to 15 °C.

CONTACT US

→ Fives Cail (France)
Tel: +33 (0)3 20 88 96 00
fivescail@fivesgroup.com

→ Fives Fletcher Limited
Tel: +44 (0)1332 636000
fivesfletcher@fivesgroup.com

→ Fives Lille do Brasil Ltda.
Tel: +55 16 3947 9029
fivescail-brasil@fivesgroup.com

→ Fives Cail - KCP Ltd.
Tel: +91 44 6677 2755
fivescail-kcp@fivesgroup.com

For more about Fives Cail ,
click here...